

Q80L series

Ø80mm LED Steady/ Flashing Signal Lights



Q80L



Q80LW

Wall mount type models allow for contained and tidy wiring with no exposed wires.



Common Specifications(Q80L/ Q80LW/ Q80LP)

- Small-sized signal light of 80mm with attractive appearance
- Shock and vibration-resistant, maintenance reduced with long-lasting energy-efficient LED light bulb
- Selectable mounts available depending on your application environment (direct mount, wall mount, pole mount)
- Materials : Lens-PC, housing-ABS, mounting bracket-PC
- Features high visibility with special diffusive lens and direct LED light distribution system
- Built-in buzzer available (Volume : Max 80dB at 1m)
- Built-in switches for steady and flashing light function mode
- Flashing rate : 60-80 flashes/min
- Ambient operating temperature : -30°C to +50°C
- Protection rating : IP65
- Certificates : CE Compliant, UL Listed
- Compliant with RoHS directive

Model number	Voltage	Current	Certificates	Weight	Color
Q80L Q80LW Q80LP	DC12V-24V	Max 0.190A	CE DC only	• Q80L-0.15kg • Q80LW-0.57kg	<ul style="list-style-type: none"> • R-Red • A-Amber • G-Green • B-Blue
	AC110V-220V	Max 0.052A	UL DC only	• Q80LP-1.09kg (Weight Above Include QZ24)	

※ DC type model has a free-voltage range of 10V-30V.

※ AC type model has a free-voltage range of 100V-240V.



Q80L Direct Mount LED Steady/ Flashing Signal Light

- Direct mount type with the three bolts/screws located on the bottom of the product



Technical Diagram

(Units : mm)

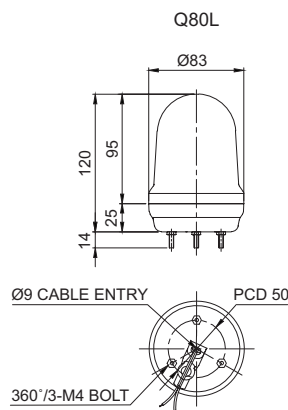

Q80LW Wall Mount LED Steady/ Flashing Signal Light

- Wall mount type with the bracket equipped



Technical Diagram

(Units : mm)

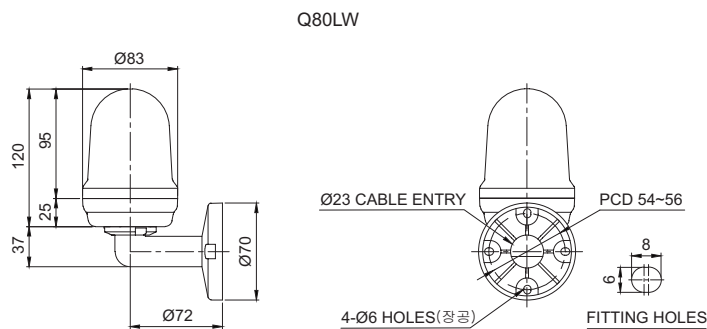

Q80L series

Ø80mm LED Steady/ Flashing Signal Lights



Q80LP

The picture for QZ24 equipped



LED Light diffusion shape of direct light distribution

High visibility with special diffusive lens and direct high brightness LED light distribution system.

Q80LP Pole Mount LED Steady/ Flashing Signal Light

- Pole mount type
- Various mounting options are available

Technical Diagram (Units : mm)

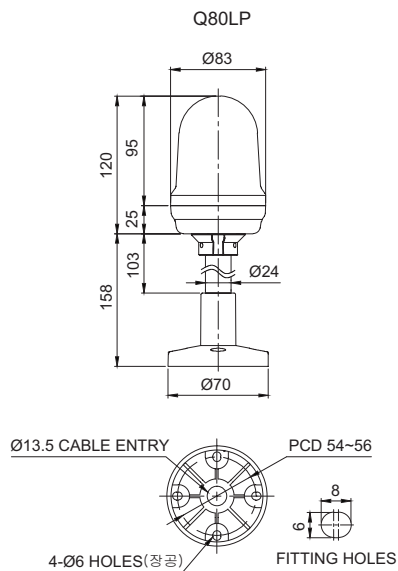

Wiring Instructions

- External power line standard : UL1015 AWG18(0.75sq)×2C 400mm
- Product can be wired regardless of polarity

Mounting Bracket

Standard	QZ24	SZ24	SL24	QLA24	
Steel	PC	Al	Al	PC	

※ Please refer to page34-39 for detailed dimension of mount bracket.

Customization

- Customized pole length available

Ordering Specification

Q80LP	-	BZ	-	12/24	-	R	-	QZ24
[Model number]		[Buzzer option]		[Voltage]		[Color]		[mount bracket]
• Q80L		• None		• 12/24		• R-Red		• None
• Q80LW		- No buzzer		- DC12V-24V		• A-Amber		- Standard
• Q80LP		• BZ		• 110/220		• G-Green		• Bracket
		- Built-in buzzer		- AC110V-220V		• B-Blue		- QZ24
								- SZ24
								- SL24
								- QLA24

