

QAD series

Signal/ LED Warning Lights with High Volume Built-in Buzzer

Wall Mount Dome Type Signal Light with Electrical Horn

Siren Buzzer 105dB, Electric Horn 100-115dB

- 6 Bit input, 5 sound tones for each group
- Binary input 30 sound tones output
- SD Card(MP3) support



• Sound Tone Selection & Volume Control

QAD series are the combination of dome type signal lights and electric horn that allow sound tone selection and volume control through a built-in control panel.

QAD series (external sound product) can support MP3 format through SD Card. (QAD100H/ QAD125H)



Common Specifications(QAD80/ QAD100/ QAD125)

- Combination of warning light and horn allow for both visual and audible signal transmission at once
- Flashing rate : 60-80 flashes/min(Built-in Steady-Flash selection switch)
- Appropriate sound tones can be chosen depending on the various working environment among various available sound tones
- Sound tone selector and volume controller in front of the device allows for convenient use
- SD Card type allows user defined sound tone
- Built-in 30 sound tones, Support Binary and Bit input modes
- Bit input mode consists of 5 sound types with 6 groups. Choose one of the groups to play 5 sounds.(MP3 does not support group)
- MP3 support(QAD100H/ QAD125H)
- Materials : Lens - PC, Housing - ABS
- Ambient operating temperature : -30°C to +50°C
- Protection rating : IP65
- Compliant with RoHS directive

Multi-functional Product

• How to Setup

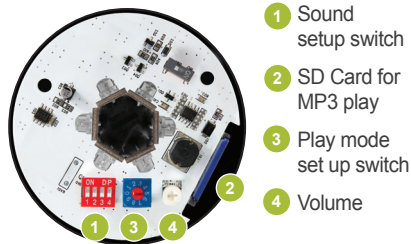

• Sound Setup Switch

Built-in sound and user-defined sound is toggled by using the sound setup switch '1'.

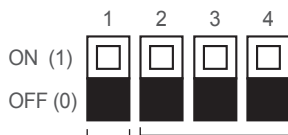

Group Choice in Bit Input Mode

- 001 : WS (5 Warning sounds)
- 010 : WP (5 special warning sounds 1st group)
- 011 : WM (5 Melodies)
- 100 : WA (5 Alarms)
- 101 : WO (5 special warning sounds 2nd group)
- 110 : WN (5 special warning sounds 3rd group)

Sound Selection

- 0 : Built-in sound
- 1 : SD Card(MP3)

- Built-in sounds(5WS, 5WP, 5WM, 5WA, 5WO and 5WN)
- Support SD Card(MP3)
- Binary Input : 30Ch
- Bit input : 5Ch(6 groups)
- Support MP3 format through SD Card
- Detailed instructions for multi-functional products are shown on page 28

30 Built-in sounds

Multi-functional product has built-in 30 sound tones

Sound	Category	Ch	Sound Tone	Sound	Category	Ch	Sound Tone
WS	5 warning sounds	Ch1	Fire.A-ANG	WA	5 alarms	Ch1	Beep Intermittent
		Ch2	Emergency WA-U(Yelp)			Ch2	Door Chime
		Ch3	Ambulance PI-PO(Hi-low)			Ch3	Phone Ring
		Ch4	Machinery Fault			Ch4	PI.PI.PI Short
		Ch5	High Expansion			Ch5	Tripping Beat
WP	5 special warning sounds (1 st group)	Ch1	Fire.A-ANG	WO	5 special warning sounds (2 nd group)	Ch1	Rel rel rel
		Ch2	Abandon Alarm			Ch2	Slow Ambulance PI-PO
		Ch3	Machinery Fault			Ch3	Wye yong Wye yong
		Ch4	High Expansion			Ch4	Phone ring 2
		Ch5	7 Short Pl. / 1 Long			Ch5	Fire.A-ANG
WM	5 melodies	Ch1	Sweet Home	WN	5 special warning sounds (3 rd group)	Ch1	Oit Oit
		Ch2	For Elise			Ch2	Pi o Pi o
		Ch3	Cuckoo's Waltz			Ch3	Slow Di o Di o
		Ch4	Piano Sonata			Ch4	Li long Li ling
		Ch5	Turkish March			Ch5	911 Siren

User-defined sound (MP3)

User-defined sound(MP3) type



Customer can create a playlist and grouping conveniently through PC. Product supports up to 32Gbyte. SD Card is an optional item.

*SD Card needs to be purchased.

MP3 file naming

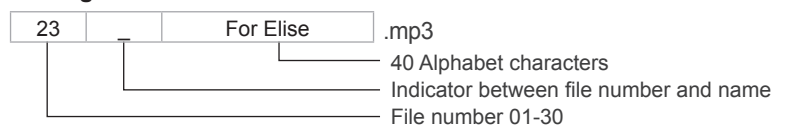

QAD series

Signal/ LED Warning Lights with High Volume Built-in Buzzer

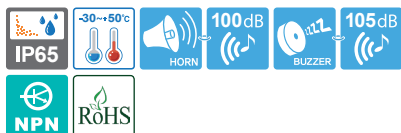

- 6 Bit input, 5 sound tones for each group
- Binary input 30 sound tones output



QAD80 series

QAD80 does not support SD Card.



QAD series buzzer and electric sound is rich and clear because the RESONANCE CHAMBER amplifies the sound.

⚠ Do not supply power into the signal line. Product may be damaged as a result

- Once powering on, signal light will work. However, the speaker will require additional wiring.

QAD80H Wall Mount Type LED Steady/ Flash & Electric Horn

- Built-in sound

Model number	Voltage	Current	Sound Pattern and volume	Certificates	Weight	Color
QAD80H	DC12V-24V	Max 0.640A	<ul style="list-style-type: none"> • Bit Input : 5Ch • Binary Input: 30Ch • Warning sounds : Max 100dB 	-	0.70kg	<ul style="list-style-type: none"> • R-Red • A-Amber • G-Green • B-Blue

※ Operating range for DC model : DC10V-30V

QAD80BZ Wall Mount Type LED Steady/ Flash & Strong Buzzer

- Built-in strong buzzer

Model number	Voltage	Current	Sound Pattern and volume	Certificates	Weight	Color
QAD80BZ	DC12V	0.500A	• Buzzer Volume : Max 105dB	-	0.75kg	<ul style="list-style-type: none"> • R-Red • A-Amber • G-Green • B-Blue
	DC24V	0.270A			0.75kg	

Technical Diagram (Units : mm)

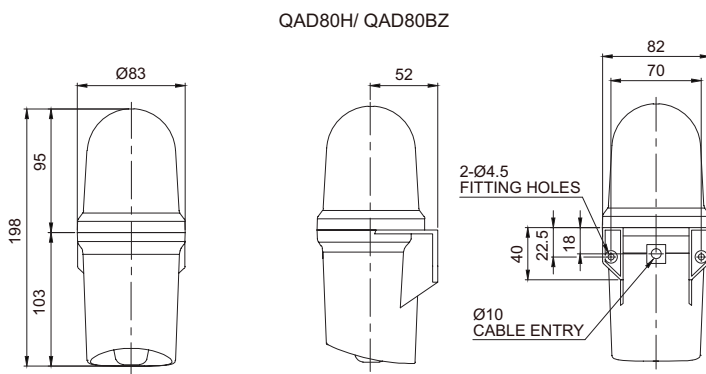

Wiring Instructions

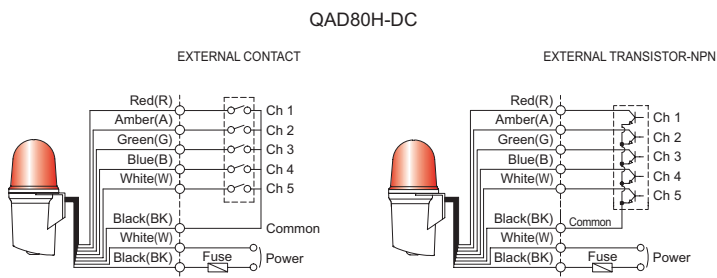

- External power line standard, UL1015 AWG18(0.75sq)×2C 400mm
- Signal line standard, UL1007 AWG22(0.3sq) 400mm
- Product can be wired regardless of polarity
- In case of 6 Bits input, 5 sound tones can be played. For Binary input, 30 sound tones can be played

※ Detailed instructions for multi-functional products are shown on page 28. (Wiring Instructions substitutes for channel selection switch)

Ordering Specification

QAD80H	-	12/24	-	R
[Model number]		[Voltage]		[Color]
• QAD80H		• 12/24-DC12V-24V		<ul style="list-style-type: none"> • R-Red • A-Amber • G-Green • B-Blue
• QAD80BZ		• 12-DC12V • 24-DC24V		

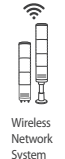
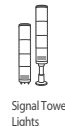

QAD series

Signal/ LED Warning Lights with High Volume Built-in Buzzer

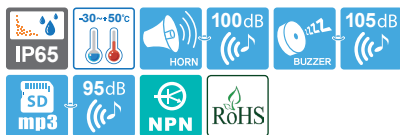

- 6 Bit input, 5 sound tones for each group
- Binary input 30 sound tones output
- SD Card(MP3) support



QAD100 series



QAD series buzzer and electric sound is rich and clear because the RESONANCE CHAMBER amplifies the sound.

⚠ Do not supply power into the signal line. Product may be damaged as a result

- Once powering on, signal light will work. However, the speaker will require additional wiring.

QAD100H Wall Mount Type LED Steady/ Flash & Electric Horn

- Built-in sound/ MP3

Model number	Voltage	Current	Sound Pattern and Volume	Certificates	Weight	Color
QAD100H	DC12V-24V	Max 1.055A	• Bit Input : 5Ch • Binary Input : 30Ch • Warning : Max 100dB • MP3 : Max 95dB	-	0.92kg	• R-Red • A-Amber • G-Green • B-Blue
	AC110V-220V	Max 0.360A			0.94kg	

※ DC type model has a free-voltage range of 10V-30V.

※ AC type model has a free-voltage range of 100V-240V.

QAD100BZ Wall Mount Type LED Steady/ Flash & Strong Buzzer

- Built-in strong buzzer

Model number	Voltage	Current	Sound Pattern and Volume	Certificates	Weight	Color
QAD100BZ	DC12V	0.550A	• Buzzer Volume : Max 105dB	-	0.98kg	• R-Red
	DC24V	0.300A				• A-Amber
	AC110V-220V	Max 0.100A				• G-Green • B-Blue

※ AC type model has a free-voltage range of 100V-240V.

Technical Diagram (Units : mm)

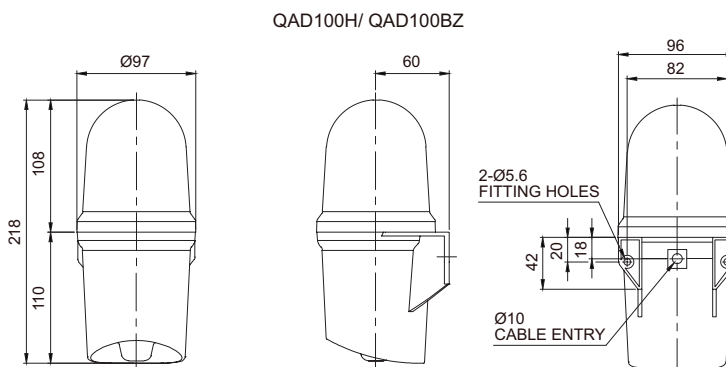

Wiring Instructions

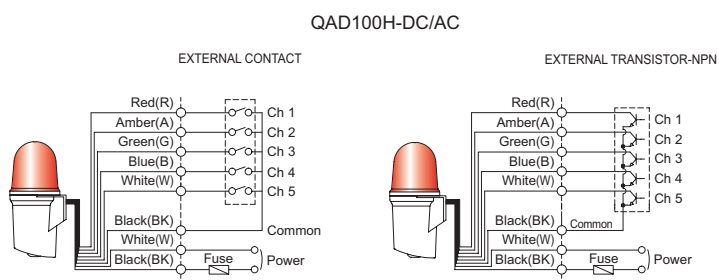

- External power line standard, UL1015 AWG18(0.75sq)×2C 400mm
- Signal line standard, UL1007 AWG22(0.3sq) 400mm
- Product can be wired regardless of polarity
- In case of 6 Bits input, 5 sound tones can be played. For Binary input, 30 sound tones can be played

※ Detailed instructions for multi-functional products are shown on page 28. (Wiring Instructions substitutes for channel selection switch)

Ordering Specification

QAD100H	-	110/220	-	R
[Model number]		[Voltage]		[Color]
• QAD100H • QAD125H		• 12/24-DC12V-24V • 110/220-AC110V-220V		• R-Red • A-Amber • G-Green • B-Blue

QAD series

Signal/ LED Warning Lights with High Volume Built-in Buzzer

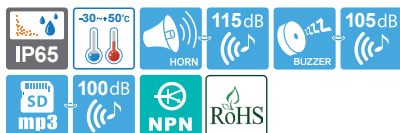

- 6 Bit input, 5 sound tones for each group
- Binary input 30 sound tones output
- SD Card(MP3) support



QAD125 series



QAD series buzzer and electric sound is rich and clear because the RESONANCE CHAMBER amplifies the sound.

⚠ Do not supply power into the signal line. Product may be damaged as a result

- Once powering on, signal light will work. However, the speaker will require additional wiring.



QAD125H Wall Mount Type LED Steady/ Flash & Electric Horn

- Built-in sound/MP3

Model number	Voltage	Current	Sound Pattern and Volume	Certificates	Weight	Color
QAD125H	DC12V-24V	Max 1.055A	• Bit Input : 5Ch • Binary Input : 30Ch • Warning : Max 115dB • MP3 : Max 100dB	-	1.12kg	• R-Red • A-Amber
	AC110V-220V	Max 0.360A			1.14kg	• G-Green • B-Blue

※ DC type model has a free-voltage range of 10V-30V.
 ※ AC type model has a free-voltage range of 100V-240V.



QAD125BZ Wall Mount Type LED Steady/ Flash & Strong Buzzer

- Built-in strong buzzer

Model number	Voltage	Current	Sound Pattern and Volume	Certificates	Weight	Color
QAD125BZ	DC12V	0.550A	• Buzzer Volume : Max 105dB	-	1.22kg	• R-Red • A-Amber
	DC24V	0.300A			1.27kg	• G-Green • B-Blue
	AC110V-220V	Max 0.100A				

※ AC type model has a free-voltage range of 100V-240V.



Technical Diagram

(Units : mm)

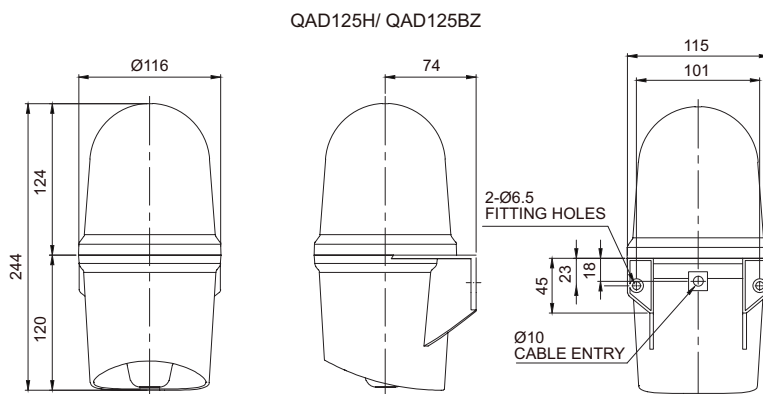

Wiring Instructions

QAD125H-DC/AC

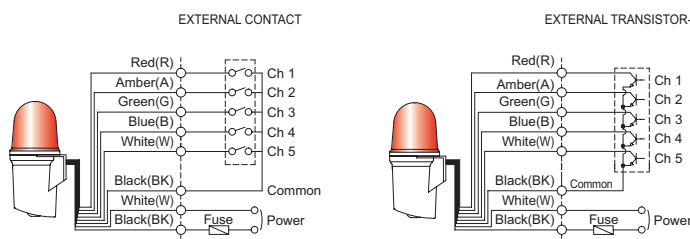

- External power line standard, UL1015 AWG18(0.75sq)×2C 400mm
- Signal line standard, UL1007 AWG22(0.3sq) 400mm
- Product can be wired regardless of polarity
- In case of 6 Bits input, 5 sound tones can be played. For Binary input, 30 sound tones can be played

※ Detailed instructions for multi-functional products are shown on page 28. (Wiring Instructions substitutes for channel selection switch)



Ordering Specification

QAD125BZ	-	24	-	R
[Model number]		[Voltage]		[Color]
• QAD100BZ • QAD125BZ		• 12-DC12V • 24-DC24V • 110/220-AC110V-220V		• R-Red • A-Amber • G-Green • B-Blue



Warning/Signal/Stackable



Signal & Electric Horn/Speakers



Vessels and Heavy-Duty Equipment



Explosion Proof



Warning Light Bar



Aviation Obstruction Lights



Signal Tower Lights



USB/ETN Signal Tower Lights



Wireless Network System



Electric Horn/Speakers



Industrial LED Lights