

QMFL-300-Ex-24

Non Sparking LED work light



QMFL-300-Ex-24 Non Sparking LED work light

- Water, vibration and oil resistant LED work lights with non sparking ex-proof feature
- Special epoxy sealed structure provides excellent oil resistance
- Aluminum housing and tempered glass improves durability and stability in hazardous areas(Explosive zone)
- Can be used for Zone 2 application with explosion proof rating of nR
- Materials : Housing-AI, Side cover-AI,
Lens-Tempered glass, Bracket-SPC1
- Certificates : KC(KGS), NEPSI
- Protection rating: Ex nR II T6, IP67/ IP69K
- Ambient operating temperature : $-40^{\circ}\text{C} \leq T_{\text{amb}} \leq +60^{\circ}\text{C}$

Specifications

Optics Specifications		
Model		QMFL-300-Ex-24
Lens color		Translucent
Light color(Standard)		Cool daylight
Color temperature(Standard)		6,000-7,000K
Luminous flux	DC	510lm
Illumination (at 1m)	DC	260Lux
Specifications		
Rated voltage		DC24V
Range of operation voltage		DC21.5V-26.5V
Current		0.410A
Power consumption		10W
Insulation resistance		Min. 100MΩ(500V DC mega ohm meter)
Withstanding voltage		DC : 500V AC, 60Hz, 1 minute
Operating temperature		$-40^{\circ}\text{C} - +60^{\circ}\text{C}$
Waterproof		IP67/ IP69K
Materials		Housing : AI, Side cover: AI, Lens: Tempered glass, Bracket: SPC-1
Certificates		
Weight(approx.)		0.79kg

Technical Diagram

(Units : mm)

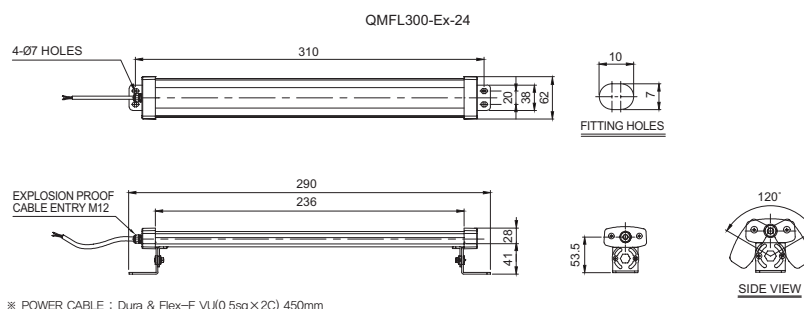

Ordering Specification

QMFL	-	300	-	Ex	-	24
[Model number]		[Length]		[Ex-proof]		[Voltage]
• QMFL : Anti glare type		• 300 : 290mm		• Ex : Non sparking ex-proof type		• 24-DC24V

- !** Cautions in use of explosion proof LED work lights
- Contact structure of an explosion proof product must be a qualified part we provide. Please do not disassemble, assemble, modify or repair arbitrarily.