

S100 series

Ø100mm Bulb Revolving Signal Lights



S100M



S100M Bulb Revolving Signal Light for Vehicle

- Three powerful magnets provide strong adhesion to the vehicle
- Power supply through cigarette lighter plug
- Protection rating : IP54

Model number	Voltage	Current	Bulb			Certificates	Weight	Color
			Spec	Standard	Parts no			
S100M	DC12V	0.966A	12V10W	T16x35 15S	9	-	0.37kg	<ul style="list-style-type: none"> ● R-Red ● A-Amber ● G-Green ● B-Blue
	DC24V	0.566A	24V10W	T16x35 15S	10			

Technical Diagram (Units : mm)

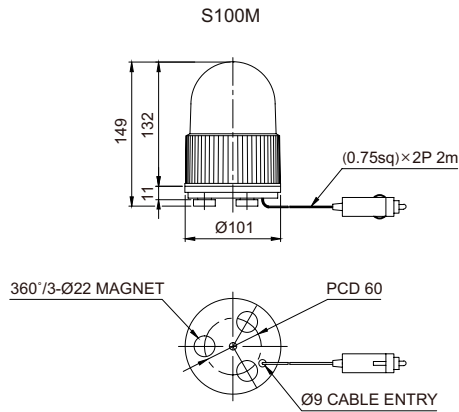

Wiring Instructions

- Cigarette lighter plug, IEC42(0.75sq)×2P 2m

Customization

- AC Type

Ordering Specification

S100M	-	BZ	-	24	-	R
[Model number]		[Buzzer option]		[Voltage]		[Color]
• S100M		<ul style="list-style-type: none"> • None • - No buzzer • BZ • - Built-in buzzer 		<ul style="list-style-type: none"> • 12-DC12V • 24-DC24V 		<ul style="list-style-type: none"> ● R-Red ● A-Amber ● G-Green ● B-Blue

