

# SE series

## Brass Housing Explosion Proof Warning/ Signal Lights



The brass housing product with excellent corrosion resistance



**SELR**



**SEL**

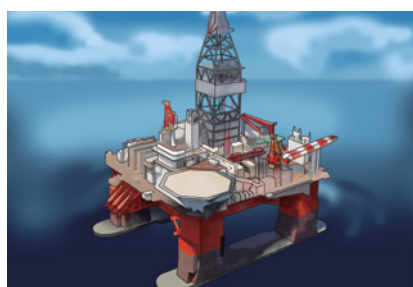

Flameproof warning/ signal lights applied in Oil/ Natural Gas offshore rigs where explosions can be ignited by mining, production, and storage as shown in the offshore rig image above.



### Common Specifications(SELR/ SEL/ SE-S/ SE)

- Brass housing explosion proof warning lights with excellent corrosion resistant
- A variety of light source selections from bulb, LED, and xenon lamp
- Fully enclosed structure with protection rating of IP66
- Integrated housing and terminal box model
- Housing standard color : MUNSELL No. 7.5BG 7/2
- Cable entry : 1/2" NPT
- Materials : Lens-Tempered glass, Inner lens-PC, Housing-AI, Protection cage-STSS 316L, Reflector for LED type-PC/ Reflector for bulb type-Heat resistant ABS
- Certificates : KIMM, ABS
- Protection rating : KIMM-Ex d IIC T6, IP66
- Ambient operating temperature :  $-40^{\circ}\text{C} \leq T_{\text{amb}} \leq +60^{\circ}\text{C}$



### SELR LED Revolving Warning Light

- Excellent omni-directional visibility with LED light collecting system and special multifaceted reflector
- Revolving speed : 120-140RPM

Model number	Voltage	Current	Certificate	Weight	Color
SELR	DC12V	0.183A	KIMM	13.35kg	<ul style="list-style-type: none"> <li>● R-Red</li> <li>● A-Amber</li> <li>● G-Green</li> <li>● B-Blue</li> </ul>
	DC24V	0.127A		13.35kg	
	AC110V	0.035A	ABS	13.91kg	
	AC220V	0.017A		13.91kg	



### SEL LED Steady/ Flashing Signal Light

- Long-lasting high intensity LED light source
- Suitable for applications where bulb replacement is hard
- Built in switch for steady/flashing selection
- Flashing rate : 60-80 flashes/min

Model number	Voltage	Current	Certificate	Weight	Color
SEL	DC12V	0.123A	KIMM	13.29kg	<ul style="list-style-type: none"> <li>● R-Red</li> <li>● A-Amber</li> <li>● G-Green</li> <li>● B-Blue</li> </ul>
	DC24V	0.094A		13.29kg	
	AC110V	0.035A	ABS	14.26kg	
	AC220V	0.017A		14.26kg	



### Customization

- Explosion proof cable gland attached type available (Standard type does not provide explosion proof cable gland)
- Customized 2 way cable entries
- Customized cable entry (3/4" NPT, M20×1.5) available

# SE series

## Brass Housing Explosion Proof Warning/ Signal Lights

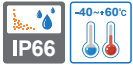

SE-S



SE

### SE-S Xenon Strobe Signal Light

- Lamp connector fastening structure allows for convenient lamp replacement
- Excellent long-distance visibility with strong strobe signal diffusion
- Flashing rate : 60-80 flashes/min

Model number	Voltage	Current	Bulb			Certificates	Weight	Color
			Spec	Standard	Parts no			
SE-S	DC12V	0.433A	200V -550V	EUB0641 -1A(G) U Type	48	  	13.53kg	<ul style="list-style-type: none"> <li>• R-Red</li> <li>• A-Amber</li> <li>• G-Green</li> <li>• B-Blue</li> </ul>
	DC24V	0.216A					13.53kg	
	AC110V	0.076A					13.51kg	
	AC220V	0.061A					13.51kg	

### SE Bulb Revolving Warning Light

- Excellent signal light diffusion effect with multi-faced reflector
- Revolving speed : 120-140RPM

Model number	Voltage	Current	Bulb			Certificates	Weight	Color
			Spec	Standard	Parts no			
SE	DC12V	1.155A	12V15W	G23 15S	17	  	13.35kg	<ul style="list-style-type: none"> <li>• R-Red</li> <li>• A-Amber</li> <li>• G-Green</li> <li>• B-Blue</li> </ul>
	DC24V	0.766A	24V15W	G23 15S	18		13.35kg	
	AC110V	0.204A	12V15W	G23 15S	17		13.91kg	
	AC220V	0.102A	12V15W	G23 15S	17		13.91kg	

### Technical Diagram

(Units : mm)

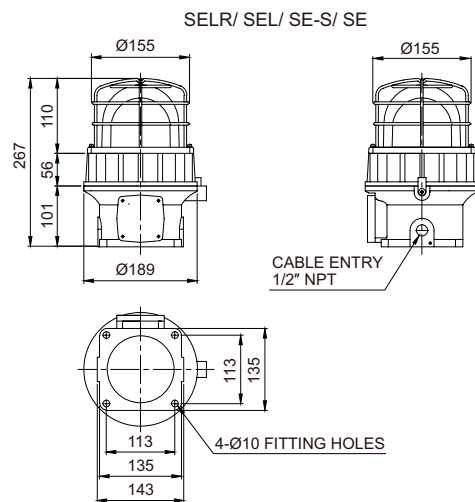

### Ordering Specification

<b>SE</b>	-	<b>220</b>	-	<b>R</b>
[Model number]		[Voltage]		[Color]
<ul style="list-style-type: none"> <li>• SELR</li> <li>• SEL</li> <li>• SE-S</li> <li>• SE</li> </ul>		<ul style="list-style-type: none"> <li>• 12-DC12V</li> <li>• 24-DC24V</li> <li>• 110-AC110V</li> <li>• 220-AC220V</li> </ul>		<ul style="list-style-type: none"> <li>• R-Red</li> <li>• A-Amber</li> <li>• G-Green</li> <li>• B-Blue</li> </ul>

