

# Smart Dupline® PIR Sensor for Ceiling and Luxmeter Type SHSBP90L



- Passive infrared detector (PIR) with built-in luxmeter
- Detects movement and presence
- Light measuring range: 0 to 20 klux
- Indoor applications
- Smart-house output
- Operating distance: max. 8 m
- Operating angle: 90°
- LED indication
- Supplied by bus
- Mounting in LK ceilingbox PL52 or PL55

## Product Description

The SHSBP90L is a 90° PIR sensor to detect presence and/or movement in indoor installations with a built-in luxmeter, combining two products in one. It is part of the smart-house concept and can be used to control lights,

rollerblinds, air-conditioning, intruder alarms and all the other functions supported by the smart-house system, in an automatic way depending on people-presence. This sensor is completely programmable via the SH tool.

## Ordering Key

**SH SB P 90 L**

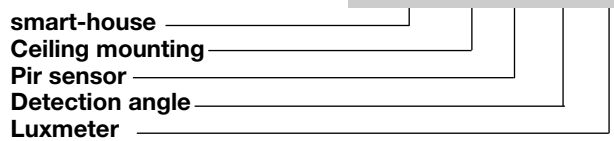

## Type Selection

Housing	Colour	LED	Supply by bus
Ø 76 x 25 mm	White	1 blue	SHSBP90L

## Input Specifications

<b>Inputs</b>	PIR
Lens	Dual detecting zones
Angle	90°
<b>Operating Distance</b>	≤ 8 m
<b>Luxmeter</b>	
Characteristic deviation	-3% to +3%
Response time	It depends on the number of variables in the system
Sensor range	0 to 20 kLux
Output accuracy over temperature	0° to 40°C ± 10% -30° to 0°C ± 15% 40° to 60°C ± 20%

## Dupline® Output Specifications

<b>Voltage</b>	8.2 V
<b>Maximum Dupline® voltage</b>	10 V
<b>Minimum Dupline® voltage</b>	5.5 V
<b>Maximum Dupline® current</b>	5 mA

## Output Specifications

<b>Output</b>	
LED output	blue LED

## Supply Specifications

<b>Power supply</b>	Supplied by bus
---------------------	-----------------

## General Specifications

<b>Address assignment</b>	Automatic: the controller recognises the module through the SIN (Specific Identification Number) that has to be inserted in the SH tool.	<b>Connection</b>	Screw terminals	0.2 to 1.5 mm <sup>2</sup>
			D+	Signal
			D-	GND
		<b>Housing</b>		LK PL-box Mechanics
		<b>Dimensions</b>		Ø 76 x 25 mm
		<b>Weight</b>		25 g
		<b>CE Marking</b>		Yes
<b>Environment</b>				
Degree of protection	IP 20			
Pollution degree	3 (IEC 60664)			
Operating temperature	0° to +50°C (+32° to +122°F)			
Storage temperature	-20° to +70°C (-4° to +158°F)			
Humidity (non-condensing)	20 to 80 %			



## General Specifications (cont.)

### EMC

- Immunity
- Electrostatic discharge
- Radiated radiofrequency
- Burst immunity
- Surge
- Conducted radio frequency
- Power frequency magnetic fields

- EN 61000-6-2
- EN 61000-4-2
- EN 61000-4-3
- EN 61000-4-4
- EN 61000-4-5
- EN 61000-4-6
- EN 61000-4-8

- Voltage dips, variations, interruptions
- Emission
- Conducted and radiated emissions
- Conducted emissions
- Radiated emissions

- EN 61000-4-11
- EN 61000-6-3
- CISPR 22 (EN55022), cl. B
- CISPR 16-2-1 (EN55016-2-1)
- CISPR 16-2-3 (EN55016-2-3)

## Mode of Operation

This PIR sensor responds to any fluctuation in infrared heat radiation, so any object or human presence changes the thermal image detected by the sensor when entering its field of vision.

The sensor is equipped with a segmented lens that divides the field of vision into active and passive zones (zones not visible to the sensor, see figures "Horizontal and Vertical sensitive area"). When a heat source crosses these zones, the sensor detects the change in infrared radiation and presence and/or movement are recognised.

How sensitive and fast the sensor has to be to detect presence and/or movement can be programmed by means of four parameters, by means of the SH tool.

The four parameters are: mode of detecting the crossing of active zones, sensitivity, the number of pulses and the time window in which these pulses have to be detected. These four parameters have to be set for both presence and movement recognition. Movement is used by the system in the intruder alarm function and to switch the light on, while presence is used in the light function to reload the energy-save timer (i.e. each time presence is detected, the energy-save timer starts counting from the beginning).

### 1) Mode of detection

A: one border between the active and the passive zone has to be crossed to give a pulse signal. This option has

to be selected for presence detection and movement and turns the light on as soon as a person moves from an active to a passive area or vice versa (very quick response). B: two borders have to be crossed to give a pulse signal. The person has to move from an active area to another active area, passing through a passive one or vice versa.

This option is recommended for sensors used in the intruder alarm function, in order to avoid false alarms.

### 2) Sensitivity

A number can be set from 3 to 100: the smaller this value is, the longer the detection distance, but the higher the sensitivity to heating sources. In the figures "Horizontal and Vertical sensitive area", three

examples of different sensitivity can be seen.

### 3) Number of pulses

The number of pulses is calculated according to mode A or B before sending a people detection message to the controller. This can be set from 1 to 8.

### 4) Time window

This is the time interval within which the predefined number of pulses is detected. It can be set from 1 to 10 seconds.

In the table below is an example of settings which, of course, might depend on environmental conditions, application and type of installation.

	Presence	Movement (light fx)	Movement (alarm fx)
Mode of detection	A	A	B
Sensitivity	10..30	30..70	50..100
Number of pulses	1	1	3
Time window	10	2	10

### Active and passive zones

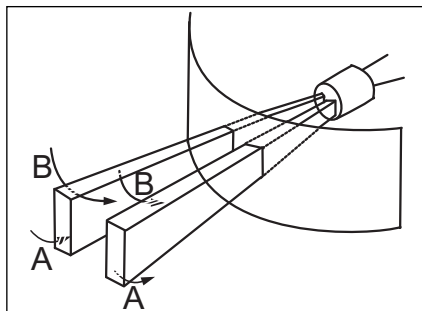

## Mode of Operation (cont.)

Horizontal sensitive area

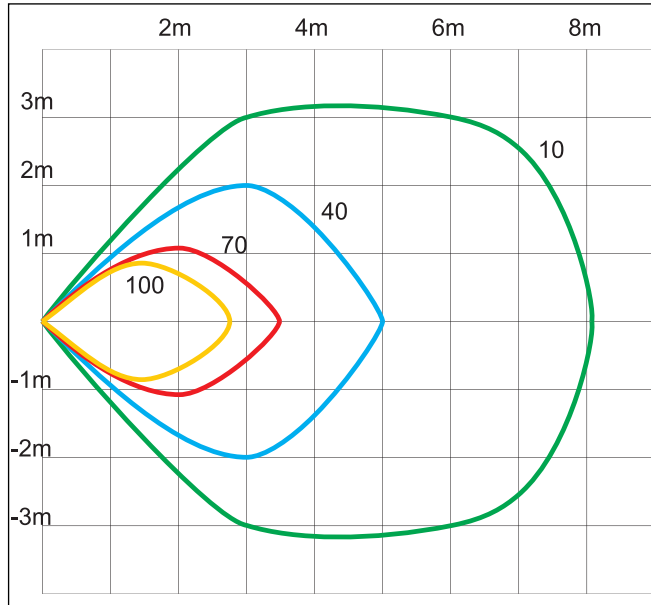

Vertical sensitive area

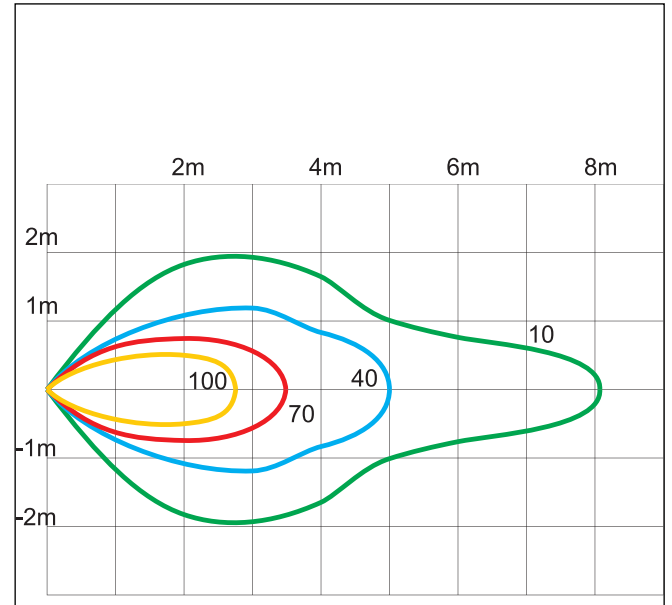

### LED programming

There is one configurable LED (blue) built-in the SHS-BP90L to be programmed.

**Blue LED:** the user can select one of the following options:

1. LED always OFF

2. LED flashes shortly every second if a presence/movement is detected
3. LED flashes shortly every second if it is used as feedback of a function status

If the blue LED is not programmed, it is always OFF.

### Coding/Addressing

No addressing is needed since the module is provided with a specific identification number (SIN): the user has only to insert the SIN number in the SH tool when creating the system configuration.

Used channels: 2 input channels, 1 output channel.

## Mounting

The PIR detector is designed for ceiling mounting. As the SHSBP90L is a passive device, several detectors can be placed in the same room without interfering with each other. The module should not be installed as follows:

- a) Outdoors.
- b) In places exposed either to sunlight or to motor vehicle headlights pointing directly at the sensor.
- c) In places exposed to direct air flow from a heater or air conditioner.
- d) In places where rapid

- e) temperature changes occur.
- f) In places exposed to severe vibration.
- g) Close to glass or other objects which might reflect the infrared radiation.

**Note:** If the sensor is to detect presence, please be careful to mount it so that

the area where presence has to be detected is completely covered by the sensitive area of the sensor. See figures "Horizontal and Vertical sensitive area".

## Wiring Diagram

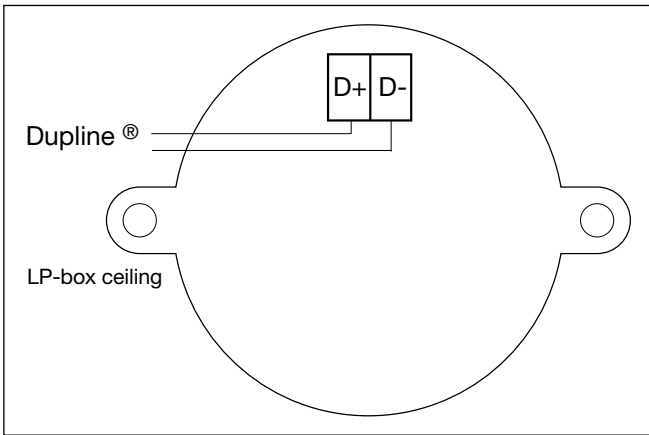

## Dimensions

