

S80 Series

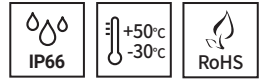

Superior light output similar to xenon lamp through novel diffusion lens



S80NS

PRODUCT SPECIFICATION

S80NS

Materials Lens-PC, Housing-ABS+GF(S80NS), ABS(S80NSE)

Ambient operating temperature -30°C to +50°C

Protection rating IP66

Flashing rate 60-80/min

Compliant with RoHS directive

- Ø80mm LED strobe signal lights
- LED lights can be strongly emitted by convex lens
- Adopts excellent light distribution structure
- LED lamp provides high durability in conveyor machines, cars, press machines which have vibration and impact
- Excellent durability and air tightness by sealed PCB
- Adopts strobe type for good visibility

S80NS LED Strobe Signal Lights

Model number	Voltage	Current	Certificates	Weight	Color
S80NS	DC12V-24V	Max.0.660A	CE UL	0.50kg	<ul style="list-style-type: none"> ● R-Red ● A-Amber ● G-Green ● B-Blue

※ DC type model has a free-voltage range of 10V-30V



S80NSE

S80NSE LED Strobe Signal Lights

Model number	Voltage	Current	Certificates	Weight	Color
S80NSE	DC12V-24V	Max.0.660A	CE UL	0.45kg	<ul style="list-style-type: none"> ● R-Red ● A-Amber ● G-Green ● B-Blue

※ DC type model has a free-voltage range of 10V-30V

※ UL compliant: DC24V

Technical Diagram

Units: mm

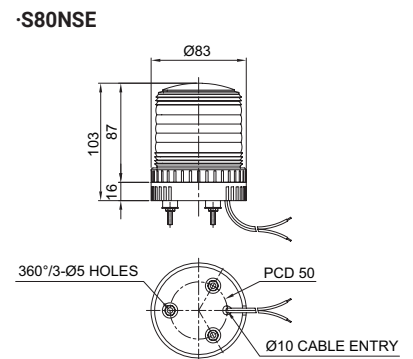
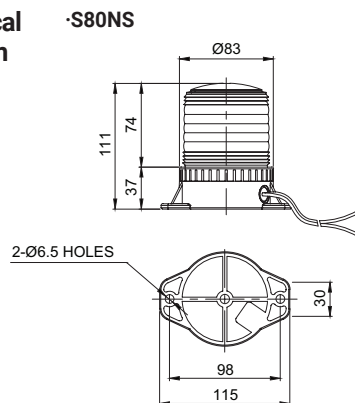

Wiring Instructions

- External Power line
UL1015 AWG18(0.75sq) x 2C 400mm
- This product can be wired regardless of polarity.

Ordering Specification

S80NS	-	12/24	-	A
[Model number]		[Voltage]		[Color]
S80NS S80NSE		12/24-DC12V-24V		<ul style="list-style-type: none"> ● R-Red ● A-Amber ● G-Green ● B-Blue